

Trouble shooting guide

Computer does not turn on?

Check to make sure that battery and ON-OFF pins are connected to DC-DC Power Supply connector.

Computer does not turn off when the ignition is turned off!

Check the Green LED state

Interpreting the Green Status LED light flashing

0.1 sec ON and 5 Sec OFF Approx.: DC-DC power supply is in Idle or stand-by state.

On constantly The PC is powered and the PC should be operating.

Error Flashes Reason

1 Flash (every 10 Sec.)	Battery voltage is below normal operating range. Voltage set by JU1 – 4, 5
2 Flashes	The computer power up sequence failed. Reasons: <ul style="list-style-type: none"> • Check the wiring of the two wire power-switch cable from power supply connector J9 to power switch pins on the ATX motherboard. If connected properly check the polarity of the power switch pins, may be reversed. • Check ATX mother board bios settings. • Locked up motherboard or software crash. • Faulty DC-DC power supply.
3 Flashes	Power supply output voltages are out of normal voltage range. Reasons: <ul style="list-style-type: none"> • Power supply output is over loaded or shorted. • Faulty DC-DC power supply.
4 Flashes	Power down, stand-by or hibernate sequence failed. Reasons: <ul style="list-style-type: none"> • Check the wiring of the two wire power-switch cable from power supply connector J9 to power switch pins on the ATX motherboard. If connected properly check the polarity of the power switch pins, may be reversed. • Check ATX motherboard bios settings. • Check if ACPI function is enabled in the power management BIOS setup. Make sure ACPI drivers are installed in the operating system. • Check if application is compatible with ACPI mode of operation. • Locked up motherboard or software crash • Faulty DC-DC power supply

Technical support: Email: tsupport@opussolutions.com

Tel: 949-305-4200

Package Contents

- 1 - DCX3.120x Automotive ATX/ITX & AT intelligent DC-DC120W Power Supply
- 1 - 20 pin ATX power cable with 2 HDD power and 1 FDD power connectors.
- 1 - 2 pin power switch cable.
- 1 - 6 pin DC input main power and IGN pigtail cable.
- 1 - Quick User guide (the one you are reading)

General Information

DCX3-120x is designed to power LOW power consumption motherboards and single board computers eg: Intel Pentium-M, AMD mobile XP, VIA C3, VIA Eden or Transmeta based computer board system. Motherboards must be ATX 2.01 and ACPI compliant or AT. Compatible with 12 or 24 Volt battery system. The Computer ON and OFF sequence is determined by the state of ignition or ON/OFF switch input.

Operating Modes

- Mode 1: System ON/OFF controlled by ON/OFF input pin (J1 – pin 3).
 - ATX mode, with ON/OFF input connected to Ignition switch ACC point or to an ON/OFF switch to battery.
 - Mode 2: System ON/OFF controlled by Front panel soft ON/OFF push button switch.
 - ATX mode, with ON/OFF input connected to battery along with +Batt leads (J1 – pins 4, 5) and J7, 2 pin power switch cable Not used.
 - Mode 3: System ON/OFF controlled by ON/OFF input pin (J1 – pin 3).
 - AT mode, (Short pins 1 and 2 of J6 with a shorting jumper). In this mode Systems handshaking are disabled.
- Note: Modes are determined with-in 3 sec of initial power connection to the DC-DC.

General wiring guidelines

Use a dedicated #12 AWG or thicker wire to connect the unit to the battery.
Use #18 AWG wire for on/off input.
Note: Do not share power cable with other equipment.

Testing the PC with DC-DC Power supply installed for proper operation

Power-up the computer by Turning the Ignition switch on (starting the vehicle) or toggling the switch on. The Green Status LED should light up constantly and the computer should power up normally.

- (Note: After connecting the power connector to the power supply, wait for DC-DC to blink twice before turning on the IGN/ ON-OFF switch input. This procedure is required only the very first time the power is applied to the DC-DC.)
1. Open any application and test for normal operation then close the application.
 2. Turn off the computer by turning the ignition switch off. Within 5-10 Sec. the PC should start to go into Standby or shut down mode and the Green status light should go back to the idle/standby blink rate.
 4. Wait about 10 seconds and Turn on the Ignition switch again. The computer should power up normally.
 5. Open an application for Standby mode testing. Use the application as you would normally.
 6. Turn off the computer by turning the ignition switch off. The computer should go into Standby, Hibernate or Shut down mode, as configured in the operating system.
 7. Repeat steps 4 to 6 for all applications that are used in your computer.

Note: All applications software must be checked for proper Standby mode operation. If any application has problem going into Standby mode then the operating system must be configured for Shutdown

DC-DC power supply Connectors

J1 - Input Power, On/Off and Remote connector

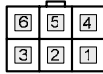

Connector type used: Molex: 39-30-1060
Mating connector type: Molex: 39-01-2060

Pin#	Function	Description	Pin#	Function	Description
1	GND	Power Ground (Input - BLK)	4	+BATT	Battery (Input - YEL)
2	GND	Power Ground (Input - BLK)	5	+BATT	Battery (Input - YEL)
3	ON/OFF	On/Off or ACC (Input - RED)	6	RMT	Remote On/Off (Output - BLU)

RMT - (optional feature) This output can be used to turn ON/OFF the remote devices such as Audio amplifier, External DVD, Camera, etc. Remote turn ON delay is set to 20 SEC. Contact sales for other custom turn ON delay

J11 – External / Remote LED connector

Pin#	Function	Description
1	LED+	To External LED Anode - output
2	LED-	To LED Cathode - output
3	OB LED-	On Board LED Cathode - input



Connector type used: Molex: 22-23-5034
Mating connector type: Molex: 22-01-3037

Factory Default Setting: Pin 1 and Pin 2 are shorted with shorting jumper for on board LED

To connect External LED: Remove shorting jumper and Connect Anode of external LED to pin 1 and cathode to pin 2

JU1 – Sht-Dwn Dly, Stnd-by Power mode and Sht-dwn / Strt-up voltage Jumpers

Pin#	Function	Description
1	SD-0	Shut Down Delay - 0
2	SD-1	Shut Down Delay - 1
3	STBY-ON	Stand-by Power ON
4	SV-0	Start-Up & Shut-Down Voltage - 0
5	SV-1	Start-Up & Shut-Down Voltage - 1

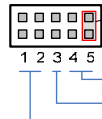

2mm Shorting Jumper installed

Start-UP & Shut-Down Voltage Select
Stanc-by Power ON/OFF
Shut-Down Delay Time select

Shut Down Delay Jumpers		Stanc-by Power ON/OFF Jumper	Start-UP & Shut-Down Voltage Jumpers	
Pin#	Time	Pin#	Start-UP Voltage	Shut-Down Voltage
0	0 - (10 Sec)	3	0	10.5V - 8.5V
1	0 - 10 Min		1	11.0V - 9.5V
0	1 - 3C Min		0	11.5V - (10.5V)
1	1 - 6C Min		1	12.0V - 11.0V

0 = Jumper not Installed
1 = Jumper Installed

When STBY-ON Jumper is installed, Stanc-by voltage is maintained after Power down. Required for Stanc-by mode operation only

(Default Factory Loading)

J7 – Power-Switch connector

Pin#	Function	Description
1	PWR-SW+	Power-Switch + (Output - GRN)
2	PWR-SW-	Power-Switch - (Output - WHT)



Connector type used: Molex: 22-23-5024
Mating connector type: Molex: 22-01-3027

Connect to Motherboard or SBC power switch pins. OBSERVE pin polarity for proper operation

J6 – PS-ON* signal and Stand-by Power connector

Pin#	Function	Description
1	GND	Ground - (BLK)
2	PS-ON*	Powersupply ON* (Input - BLU)
3	5V STBY	+5V Stand-by power (output - PUR)



Connector type used: Molex: 22-23-5034
Mating connector type: Molex: 22-01-3037

Factory default is ATX mode operation. For AT mode operation: Short Pin 1 to 2 with a shorting jumper.
Note: J6 Connector is loaded only on DC-DC's with Stand-By power circuit loading

Recommended Installation Steps

- Step 1. Configure DC-DC JU1 jumpers. STBY-ON and Start-up and shut down voltages. Install OPUS DC-DC in the system.
 - Step 2. Configure ATX/ ITX motherboard BIOS: Turn off AC power loss auto restart, ACPI: S3, Push btn: Instant off.
 - Step 3. Configure operating system: Power-down, hibernate or Stand-by mode.
 - Step 4. Test the PC for proper operation. If all passes then, configure the DC-DC shut down delay jumpers if required.
- Suggestion: Configure and test system with a standard AC- DC ATX power supply first. Then switch over to OPUS DC-DC power supply.

DC-DC Application Example

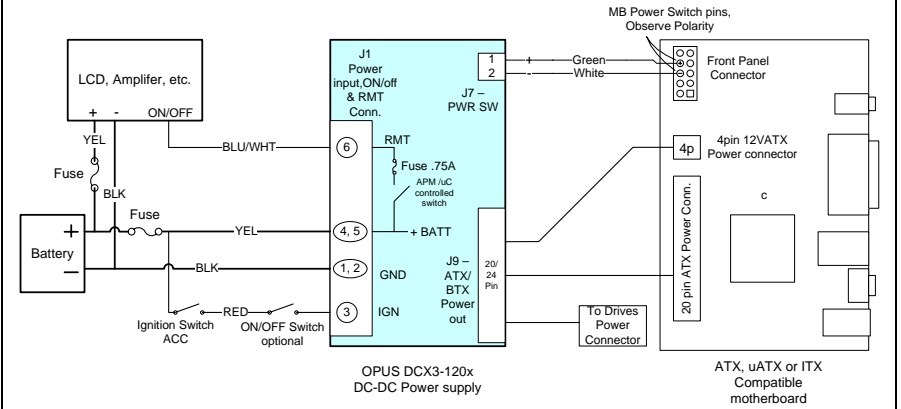

DCX3 DC-DC PCB Dimensions

